

Technical specification

avus 500 plus NG



Design:

550 kW el.

60 Hz / 480 V

natural gas

Calorific Value = 990 BTU/ft³

NO_x < 1,0 g/BHP-h

Exhaust cooling to 248 °F

1. Genset	3
1.1 Engine	3
1.2 Generator (utility planning data)	4
2 Mixture composition	4
2.1 Combustion air	4
2.2 Fuel	5
3 Integrated heat extraction	5
3.1 Customer Heat Recovery Circuit	5
3.2 Engine circuit	5
3.3 Mixture cooling water circuit - low temperature (LT)	5
4. Exhaust system	6
5 Ventilation	6
6 Operating fluids	6
7 Electronics and software	6
8 Interfaces	7
8.1 Dimensions and weights	7
8.2 Mechanical Connections	8
8.3 Electrical connections / utility interface	8
8.4 Data interfaces	8
9 Technical boundary conditions	9

Subject to technical changes!

Note: Figure on cover page may differ

1. Genset

	50 %	75 %	100 %	Load
Electrical power	275	413	550	kW ⁽⁵⁾
Recoverable thermal output	1324	1668	2085	MBTU/hr ⁽²⁾
Fuel consumption	2486	3539	4622	MBTU/hr ⁽¹⁾
Efficiency Electrical	37,7	39,8	40,6	% ⁽¹⁾
Efficiency Thermal	53,3	47,1	45,1	% ^{(1), (2)}
Efficiency Combined (el. + th.)	91,0	86,9	85,7	% ^{(1), (2)}
	NOx	CO	VOC ⁽⁸⁾	
Exh. emissions without catalytic converter	< 1,0	< 2,0	< 0,7	g/BHP-h
	< 244	< 801		ppm ^{(4),(6)}
Exh. emissions with catalytic converter	< 1,0	< 0,6	< 0,7	g/BHP-h
	< 244	< 240		ppm ^{(4),(6)}
Engine surface noise **			112	dB(A) ⁽⁷⁾
Engine surface noise with sound enclosure (optional) ***			70	dB(A) ⁽⁷⁾

1.1 Engine

Engine manufacturer	2G		
Engine type	agenitor 412		
Type	V - Motor		
No. of cylinders	12		
Operating method	4-stroke		
Engine displacement	25007	ccm	
Bore	5,12	in	
Stroke	6,18	in	
RPM	1800	1/min	
ISO standard power (mech.)	769	bhp	
compression ratio	13 : 1		
average effective pressure	221,8	psi	
average piston speed	30,9	ft/s	
body of balance wheel	SAE 1		
Direction of rotation (based on balance wheel)	left		
tooth rim with number of teeth	137		
Engine dead weight	4740	lbs	
Mixture cooling to	122	°F	

** Total sound power level at full engine load in accordance with DIN EN ISO 3746

*** Average sound pressure level under open area conditions at distance of 1 m in accordance with DIN 45635

An increased noise load must be taken into account with fresh air intake from the installation room.

1.2 Generator (utility planning data)

Manufacturer	Leroy Somer	
Type	LSA 49.3.S4/4p	
Generator type	Synchronous, directly coupled	
Voltage regulator (AVR)	D510C	
Rated speed	1800	1/min
Frequency	60	Hz
Effective electrical power	550	kW
Apparent electrical power (cos φ 0.8)	688	kVA
Apparent electrical power (cos φ 1.0)	550	kVA
Rated generator current (cos φ 0.8)	827	A
Rated generator current (cos φ 1.0)	662	A
Rated generator voltage (\pm 10 %)	480	V
Subtransient reactance X"d	15,2	%
Short-circuit current I _k "3	6,8	kA
Power factor cos φ (lagging / leading)	0.8 / 0.95	
Generator circuit breaker	1000	A
Additional section switch (VDE-AR-N 4105)	1000	A
Efficiency (full load) at Cos φ = 1	95,9	%
Mass moment of inertia	188,89	lb · ft ²
Ambient air temperature	104	°F
Stator circuit	star	
Protection class	IP 23	
Generator weight	3269	lbs
Compensation	not available	
Engine startup	not available	

2 Mixture composition

2.1 Combustion air

Combustion air mass flow	6469	lbs/hr
Combustion air volume flow (25 °C, 1013 mbar)	1459	SCFM

2.2 Fuel

Fuel requirements in accordance with 'TA-004 Gas'

Reference methane number - minimum methane number	80 / 80	
Combustible mass flow	233,8	lbs/hr ⁽¹⁾
Combustible volume flow	77,8	SCFM ^{(6)^(1)}
Gas pressure at rated load min. *	0,435	psig
Gas flow pressure at rated load max. *	1,015	psig
Gas regulation line safety pressure	5,221	psig

* At the inlet to the gas regulation line

3 Integrated heat extraction

3.1 Customer Heat Recovery Circuit

Heating water requirements in accordance with 'TA-002 Heating circuit'

Heating water volume flow (at $\Delta t = 59$ °F)	154,1	gpm
Internal pressure loss in heating circuit (approx.) *	4,35	psig
Pressure reserve (approx.) *	20,10	ft
Heating water return temperature (max)	158	°F
Heating water flow temperature (max) **	194	°F
Safety valve	87,02	psi

3.2 Engine circuit

Coolant requirements in accordance with 'TA-001 Coolant'

Jacket Water Heat	737,499	MBTU/hr
Exhaust Gas Heat up to 248°F	1101,918	MBTU/hr
Engine inlet temperature (min.)	176	°F
Engine outlet temperature (max.)	190	°F
Differential inlet / outlet (max.)	10,8	°F
Engine jacket water flow (min.)	158,6	gpm
Total cooling water circulation volume	264,3	gpm
Operating pressure (max.)	29,0	psi
Safety valve	43,5	psi
Safety temperature limiter	230	°F
Intercooler heat high temperature circuit	245,780	MBTU/hr
Intercooler inlet high water temperature (max.)	180	°F
Intercooler coolant flow high temperature circuit (min.)	105,7	gpm

3.3 Mixture cooling water circuit - low temperature (LT)

Coolant requirements in accordance with 'TA-001 Coolant'

Intercooler heat low temperature circuit	175,207	MBTU/hr
Intercooler inlet low water temperature (max.)	100	°F
Intercooler outlet low water temperature (max.)	106	°F
Intercooler coolant flow low temperature circuit (min.)	75,4	gpm
Safety valve	44	psi

* Up to / from module interface

** Heating water supply temperature in partial load operation < 90°C

4. Exhaust system

Exhaust gas temperature after turbo charger	863	°F ⁽³⁾
Exhaust temperature after exhaust heat exchanger	248	°F
exhaust gas volume flow wet	1408	SCFM ⁽⁶⁾
exhaust gas volume flow dry	1261	SCFM ⁽⁶⁾
exhaust gas mass flow wet	6703	lbs/hr
exhaust gas mass flow dry	6232	lbs/hr
Exhaust back pressure downstream of turbine max.	0,73	psig
Pressure reserve approx. *	0,38	psig
Exhaust outlet noise **	130	dB ⁽⁷⁾

5 Ventilation

Radiation heat of engine and generator (approx.)	303,729	MBTU/hr
Supply air volume flow min. (at $\Delta t = 15$ K)	12026	SCFM

6 Operating fluids

Lubricating oil approvals, see 'TA-003 Lubricating oil'

Lubrication oil consumption (max.)	0,20	g/kWh
Filling capacity lubricant (max.)	23,78	gallons
Lubricating oil filling tank fill capacity ***	-	gallons
Lubricating oil volume extension tank (optional)	42,27	gallons

Coolant approvals, see 'TA-001 Coolant'

7 Electronics and software

Generator Protection Relay	Deif GPC 3 optional redundant Relay SEL 700GT	
Touchscreen display	10	"
Protection class Control cabinet	Type 12	
Protection class Power switch cabinet	Type 1	
Switch cabinet environmental temperature	32 - 95	°F
Switch cabinet relative air humidity (max.)	65	%

* From module interface (exhaust heat exchanger / catalytic converter in standard version and new condition)

** Total sound power level at full engine load in accordance with DIN 45635-11 Annex A

*** Filling tank omitted with installation of a lubricating oil volume auxiliary tank

8 Interfaces

8.1 Dimensions and weights

(Figures may differ)

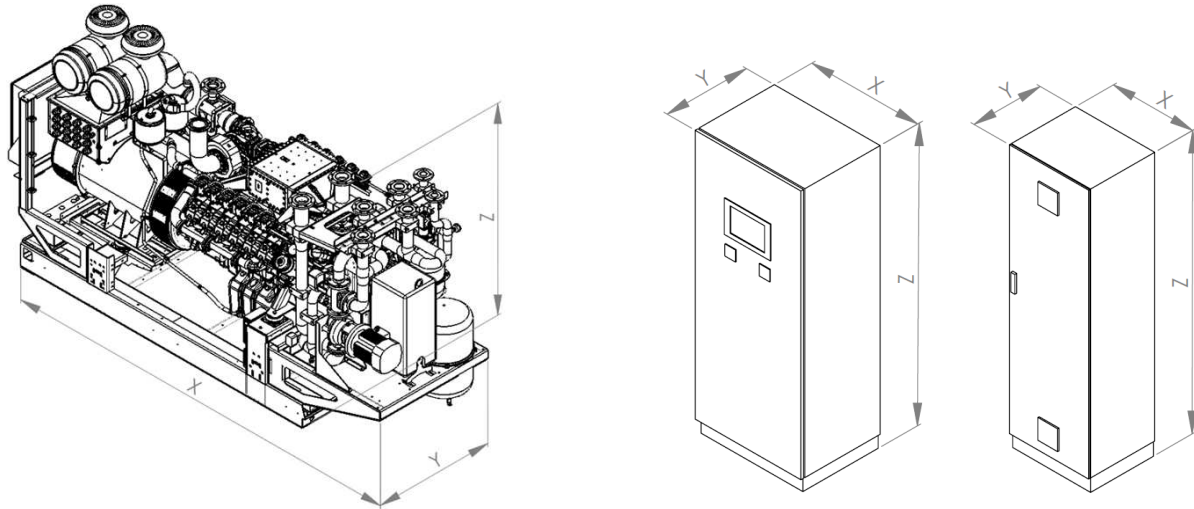

Length Module	X	168,31	in
Width Module	Y	51,57	in
Height Module	Z	86,61	in
Weight Module		13558	lbs
Weight Module with sound enclosure (optional)		16645	lbs
Powder-coated CHP frame		RAL 6002	
Width Control cabinet	X	39,37	in
Depth Control cabinet	Y	23,62	in
Height Control cabinet	Z	82,68	in
Weight Control cabinet		441	lbs
Control cabinet powder coated		RAL 7035	
Width Power switch cabinet	X	23,62	in
Depth Power switch cabinet	Y	19,69	in
Height Power switch cabinet	Z	78,74	in
Weight Power switch cabinet		331	lbs
Power switch cabinet powder coated		RAL 7035	

8.2 Mechanical Connections

Interface Gas	50 / 10	DN / PN
Interface Exhaust	/	DN / PN
Interface Heating circuit	80 / 16	DN / PN
Interface Emergency cooling circuit	80 / 16	DN / PN
Interface Mixture cooling circuit LT	50 / 16	DN / PN

8.3 Electrical connections / utility interface

Grid connection with pre-fuse (customer-provided)	60 Hz / 480 V	
Grid system	Y	
Short-circuit proof I _{cc} (max.)	50	kA

8.4 Data interfaces

Remote maintenance access (optional) *	DSL / UMTS (SIM)
Interfaces / Data interfaces (optional):	<ul style="list-style-type: none">- Profibus- Profinet- Modbus RTU- Modbus TCP- Ethernet IP- Hardware signals
Access virtual power plant (optional)	Possible after technical clarification (bus or hardware signals)

* Access for remote maintenance must be provided by the customer

9 Technical boundary conditions

Unless otherwise specified, all data is based on full engine load with the respective indicated media temperatures and subject to technical improvements. The generator output measured at the generator terminals serves as the basis for the delivered electrical power. All power and efficiency specifications are gross specifications. The fuel gas quality must conform to the specifications of 'TA-004 Gas'. The operating fluids and plant system layout must conform to the 'Technical instructions' of 2G.

- (1) Performance conditions in accordance with DIN ISO 3046. Tolerance for specific fuel use amounts to + 5% of nominal performance. Efficiency specifications are based on an engine in new condition. An abatement in efficiency over the service life is reduced with observance of the maintenance requirements.
- (2) The tolerance for usable heat output is +/- 8 % under normal load.
- (3) The tolerance for the exhaust temperature is +/- 8 %.
- (4) Corresponding to a residual oxygen concentration in the exhaust of 5 %.
- (5) Electrical generator terminal power at $\cos \varphi = 1.0$
- (6) Volume specifications for normal status:

Pressure	14,69 psig
Temperature	32 °F
- (7) Standard deviation of reproducibility 4 dB in accordance with DIN EN ISO 3746
- (8) Assumed gas composition (VOC calculated as NMHC):
CH₄=90 %, C₂H₆=3 %, C₃H₈=2 %, C₄H₁₀=0,5 %, CO₂+N₂=4,5 %

Power specifications in this document relate to standard reference conditions.

Standard reference conditions in accordance with DIN ISO 3046-1:

Air pressure	14,50 psig
Air temperature	77 °F
Relative air humidity	30 %

Power reduction

Power reduction due to installation at altitude > 958ft a.s.l. and/or air suction temperature > 77°F shall be determined specifically for each project according "TI-049 Load reduction".